

Section N-N

| Part No. | 75x50-C | 75-C | 100-C | 125-C | 150-C | 200-C | 250-C | 300-C | 400-C | |
|-----------------|---------|---------|-------|-------|-------|-------|-------|-------|-------|-------|
| | mm | 20x15 | 20 | 25 | 32 | 40 | 50 | 65 | 80 | 100 |
| | inches | 3/4x1/2 | 3/4 | 1 | 1-1/4 | 1-1/2 | 2 | 2-1/2 | 3 | 4 |
| A | | 116 | 116 | 126 | 179 | 186 | 196 | 208 | 251 | 280 |
| B | | 54 | 54 | 61 | 84 | 91 | 101 | 113 | 138 | 166 |
| ØC | | 32.4 | 32.4 | 37.2 | 46 | 54 | 63.8 | 76.5 | 92.2 | 120.2 |
| ØF | | 8 | 13 | 19 | 24 | 31.5 | 42 | 53 | 66.5 | 87.5 |
| ØG ₁ | | 14.8 | 20.6 | 27 | 33.9 | 40 | 52.4 | 65 | 77.7 | 103 |
| ØG ₂ | | 12 | 19 | 25 | 32 | 38 | 50 | 63 | 74.5 | 100 |
| I | | 36 | 56.5 | 61.5 | 65 | 67 | 80 | 94 | 107 | 109 |
| H | | 32.5 | 31.5 | 39.5 | 46 | 46 | 53 | 56 | 57 | 61 |
| L | | 68.5 | 88 | 101 | 111 | 113 | 133 | 150 | 164 | 170 |
| Weight(kg) | | 0.1 | 0.11 | 0.17 | 0.33 | 0.33 | 0.42 | 0.62 | 0.8 | 1.32 |

Units:mm

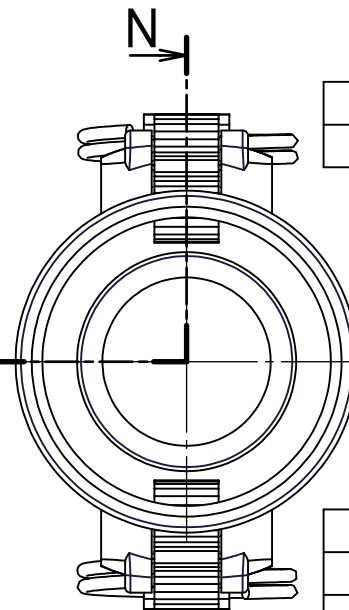
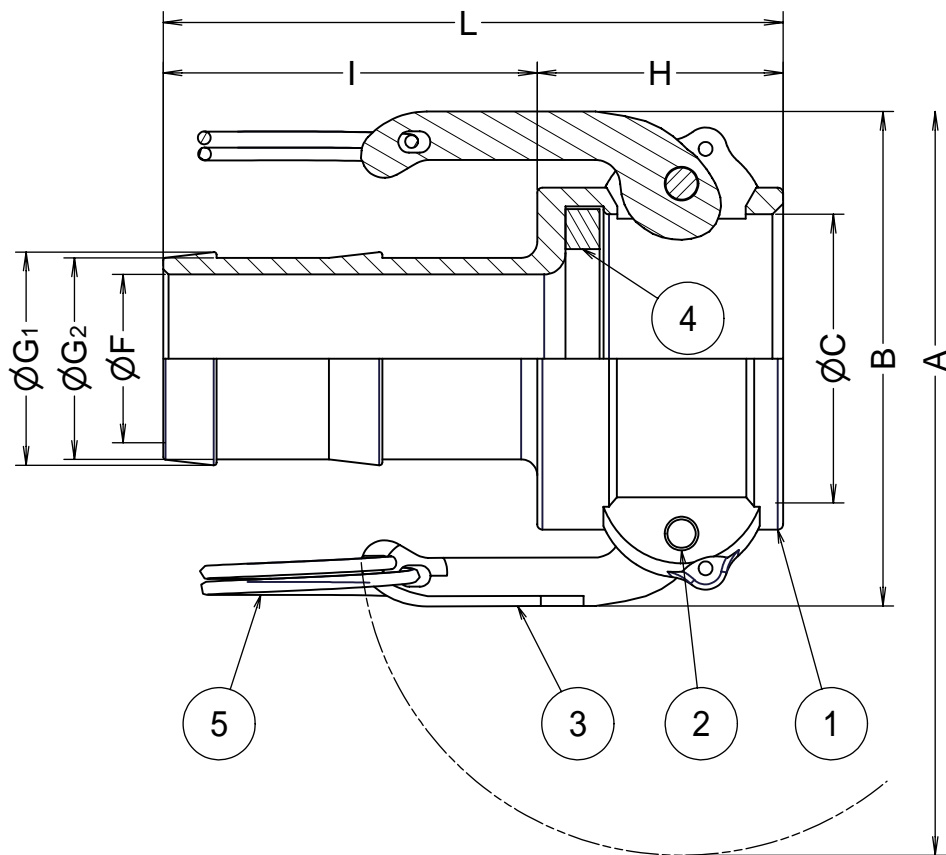

| | | | | |
|---|-------|--------|---|--|
| 5 | リング | SUS304 | 2 | |
| 4 | ガスケット | BUNA-N | 1 | |

| | | | | |
|---|-------|---------|---|--|
| 3 | カムアーム | SUS304 | 2 | |
| 2 | ピン | SUS304 | 2 | |
| 1 | ボディ | AC4D-T6 | 1 | |

| ITEM | PART NAME | MATERIAL | Q'TY | REMARKS |
|------|-----------|----------|------|---------|
|------|-----------|----------|------|---------|

| | | | | | |
|-----------------|-------|------|------|------------------------------------|--|
| CUSTOMER | | | | TITLE | |
| | | | | MAX-LOK | |
| | | | | MAX-C ホースシャンクカップラー | |
| DATE | SCALE | DRAW | APPR | FULLNESS JAPAN CORPORATION. | |
| Feb.16'06 | none | ToMo | | | |
| DWG No. | | | 3 | | |
| MAX-C-01AL-AC4D | | | | | |