

POLYPROPYLENE

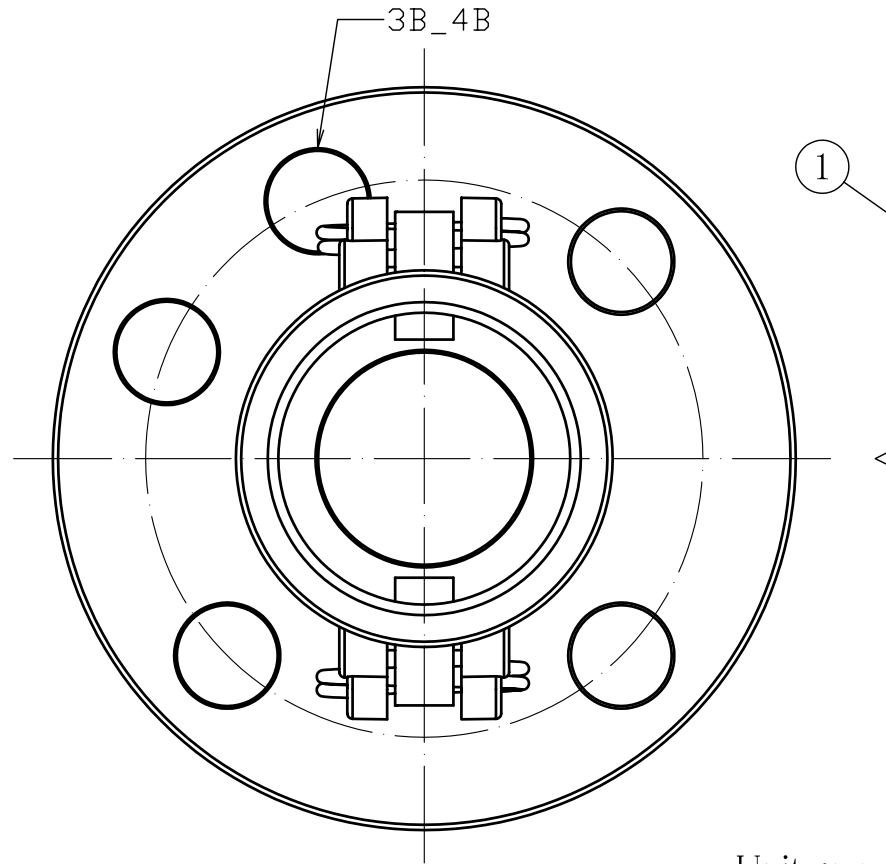

Units;mm

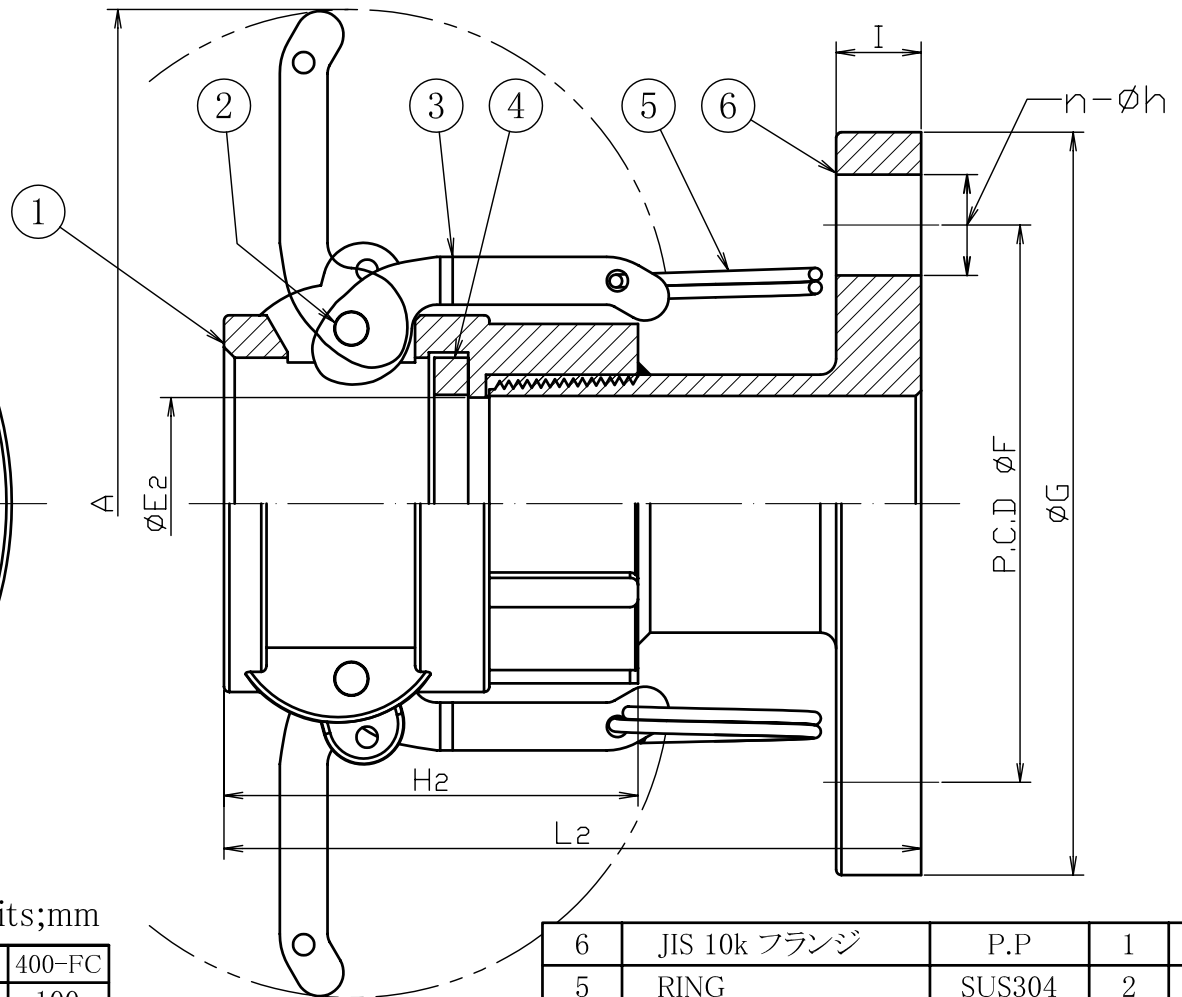

PART No.	75-FC	100-FC	125-FC	150-FC	200-FC	300-FC	400-FC	
SIZE	A	20	25	32	40	50	80	100
	B	$\frac{3}{4}$	1	$1\frac{1}{4}$	$1\frac{1}{2}$	2	3	4
A	115	125	177	185	195	249	279	
ϕE_2	20	27	34	43	51	76	102	
ϕF	75	90	100	105	120	150	175	
ϕG	100	125	135	140	155	185	210	
H_2	50	62	64	78	84	90	92	
I	14	14	16	16	16	18	18	
n	4	4	4	4	4	8	8	
ϕh	15	19	19	19	19	19	19	
L_2	74	100	127	132	134	162	166	

ITEM	PART NAME	MATERIAL	Q'TY	REMARKS
6	JIS 10k フランジ	P.P	1	
5	RING	SUS304	2	
4	GASKET	NBR	1	
3	CAM ARM	SUS304	2	
2	PIN	SUS304	2	
1	MAX-D アダプター	P.P	1	

Nominal Dia.	
Fluid	
Press.	
Temp.	
Drawing History	

CUSTOMER			
DATE	SCALE	DRAW	APPR
Jan.15'02	none	ToMo	
DWG No.			3
MAX-FC-05PP-10			

TITLE

MAX-LOK

MAX-FC フランジカップラー

 FULLNESS JAPAN CORPORATION