

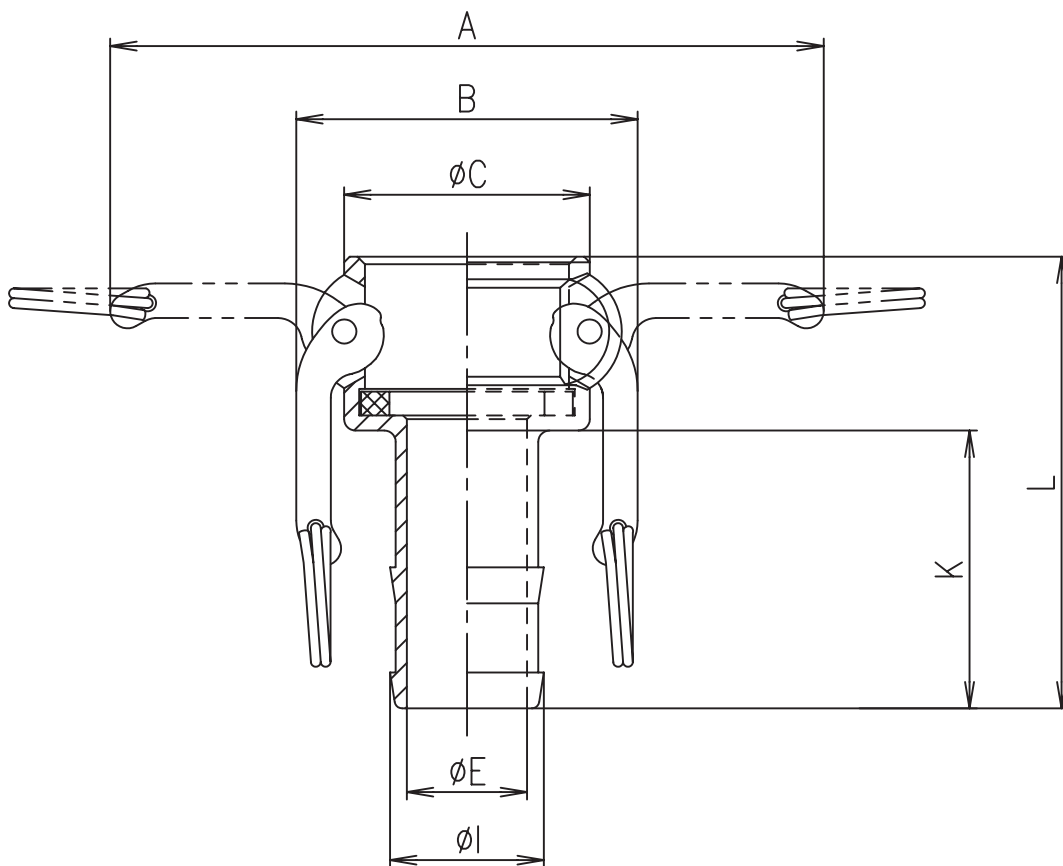

BILL OF MAT'L

ITEM	REQ.		MAT'L	DESCRIPTION
	WORKING	SPARE		



Dimensional sketch for SST Kamlok-coupler·hose·shanks 633-C												
dim.	1/2"	3/4"	1"	1.1/4"	1.1/2"	2"	2.1/2"	3"	4"	5"	6"	8"
A	—	116	125	181	189	199	210	254	282	307	409	474
B	—	54	61	83	91	101	112	138	166	191	255	320
C	—	41	47	58	65	75	90	108	140	165	198	264
E	—	14	20	25	32	45	57	68	89	114	142	188
I	—	21	28	34	41	53	67	80	105	134	157	207
K	—	51	57	58	60	72	84	104	115	127	146	150
L	—	82	98	104	107	124	140	162	174	189	214	252
Dimensions in mm.												

TITLE Kamlok coupler·hose·shank 633-C SST	CUSTOMER			NO.
	MAT'L SST	DRAWN	DATE 98,05,12	REFERENCE
株式会社トヨックス	WEIGHT	CHECKED		
	SCALE NONE	APPROVED	DWG. NO. CDS-S-77	

△				BILL OF MAT'L	
	ITEM	REQ.		MAT'L	DESCRIPTION
	WORKING	SPARE			

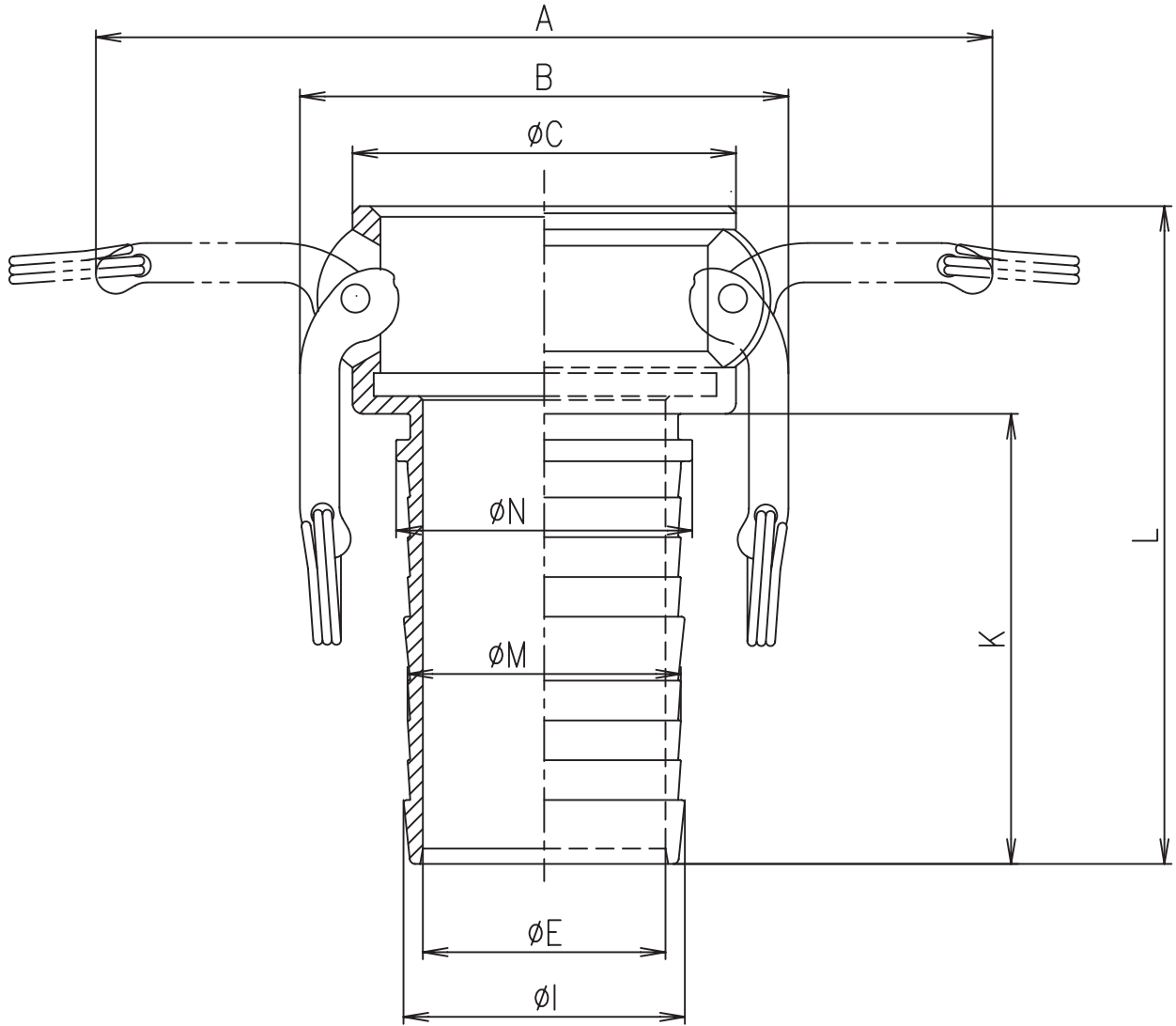

Dimensional sketch for SST Kamlok-coupler·hose·shanks.633-C

dim	3/4"	1"	1.1/4"	1.1/2"	2"	2.1/2"	3"	4"
A	116	125	181	189	199	210	254	282
B	54	61	83	91	101	112	138	166
C	41	47	58	65	75	90	108	140
E	14	20	25	32	44	56	68	90
I	21	27	34	40	53	67	79	105
K	62	69	74	89	105	104	127	140
L	94	110	121	136	157	160	185	200
M	20	26	33	39	52	65	77	103
N	25	31	38	44	58	71	83	111

TITLE 633-C SST 株式会社トヨックス	CUSTOMER			NO.
	MAT'L SST	DRAWN	DATE 05.01.11	REFERENCE
	WEIGHT	CHECKED		
	SCALE 1/2	APPROVED	DWG. NO.	CDS-S-577 △