

△	BILL OF MAT'L				
	ITEM	REQ.		MAT'L	DESCRIPTION
		WORKING	SPARE		

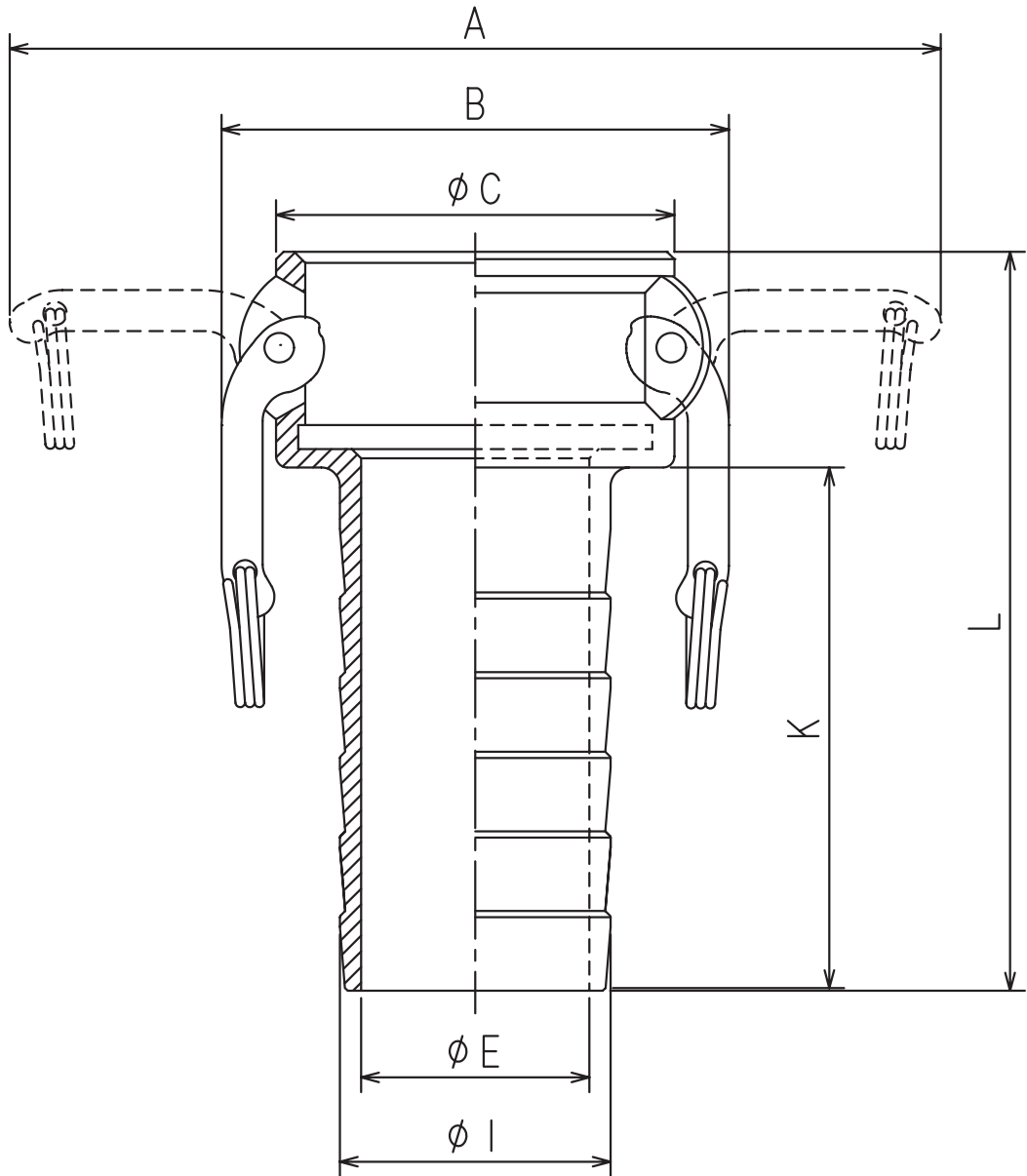

Dimensional sketch for AL Kamlok-coupler-hose-shanks. 633-CT

dim	1. 1/2"	2"	2. 1/2"	3"	4"	5"	6"
A	189	199	210	254	282	307	409
B	91	101	112	138	166	191	255
C	65	75	90	108	140	165	198
E	31	43	55	67	92	117	142
I	38	51	64	77	102	127	152
K	87	98	105	120	128	127	143
L	134	150	161	179	189	189	211

TITLE 633-CT AL	CUSTOMER			NO.
	MAT'L	DRAWN	DATE	REFERENCE
株式会社 トヨックス	WEIGHT	CHECKED		
	SCALE None	APPROVED	DWG. NO.	△