

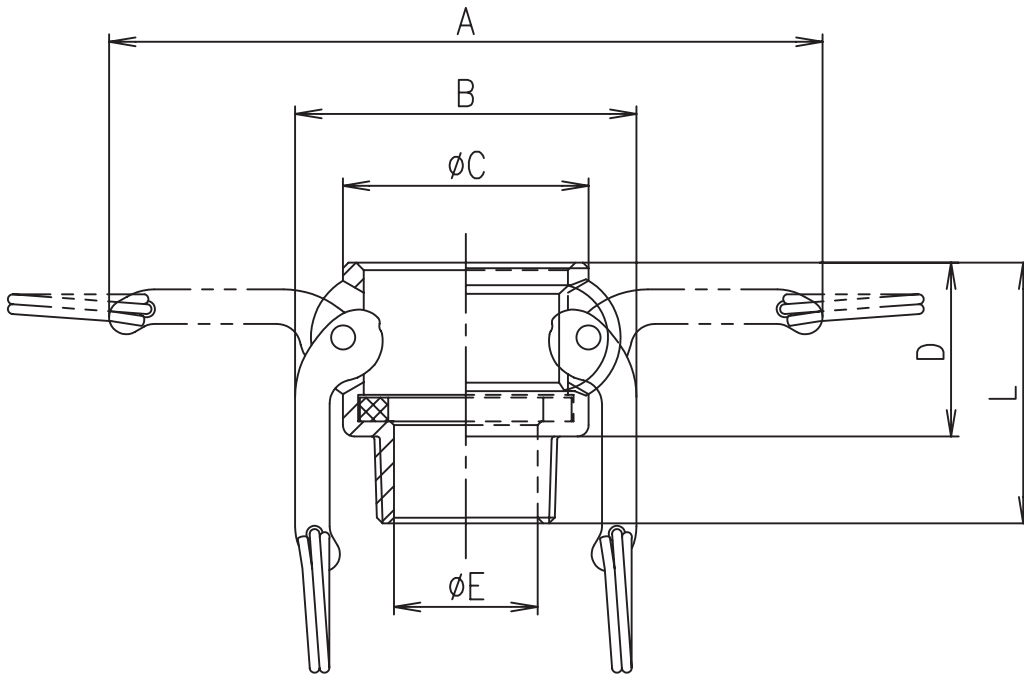

BILL OF MAT'L

ITEM	REQ.		MAT'L	DESCRIPTION
	WORKING	SPARE		



Dimensional sketch for SST Kamlok-couplers. 633-BB											
dim.	1/2"	3/4"	1"	1.1/4"	1.1/2"	2"	2.1/2"	3"	4"	5"	6"
A	116	116	125	181	189	199	210	254	282	307	409
B	54	54	61	83	91	101	112	138	166	191	255
C	41	41	47	58	65	75	90	108	140	165	198
D	32	32	41	47	47	52	56	59	59	60	73
E	14	19	25	32	38	49	61	76	94	126	149
L	50	52	64	73	73	82	89	95	102	105	116
Dimensions in mm.											

TITLE Kamlok coupler. 633-BB SST	CUSTOMER			NO.
	MAT'L SST	DRAWN	DATE 98,05,12	REFERENCE
株式会社トヨックス	WEIGHT	CHECKED		
	SCALE NONE	APPROVED	DWG. NO. CDS-S-76	△