

△	BILL OF MAT'L			
	ITEM	REQ.		MAT'L
WORKING		SPARE		

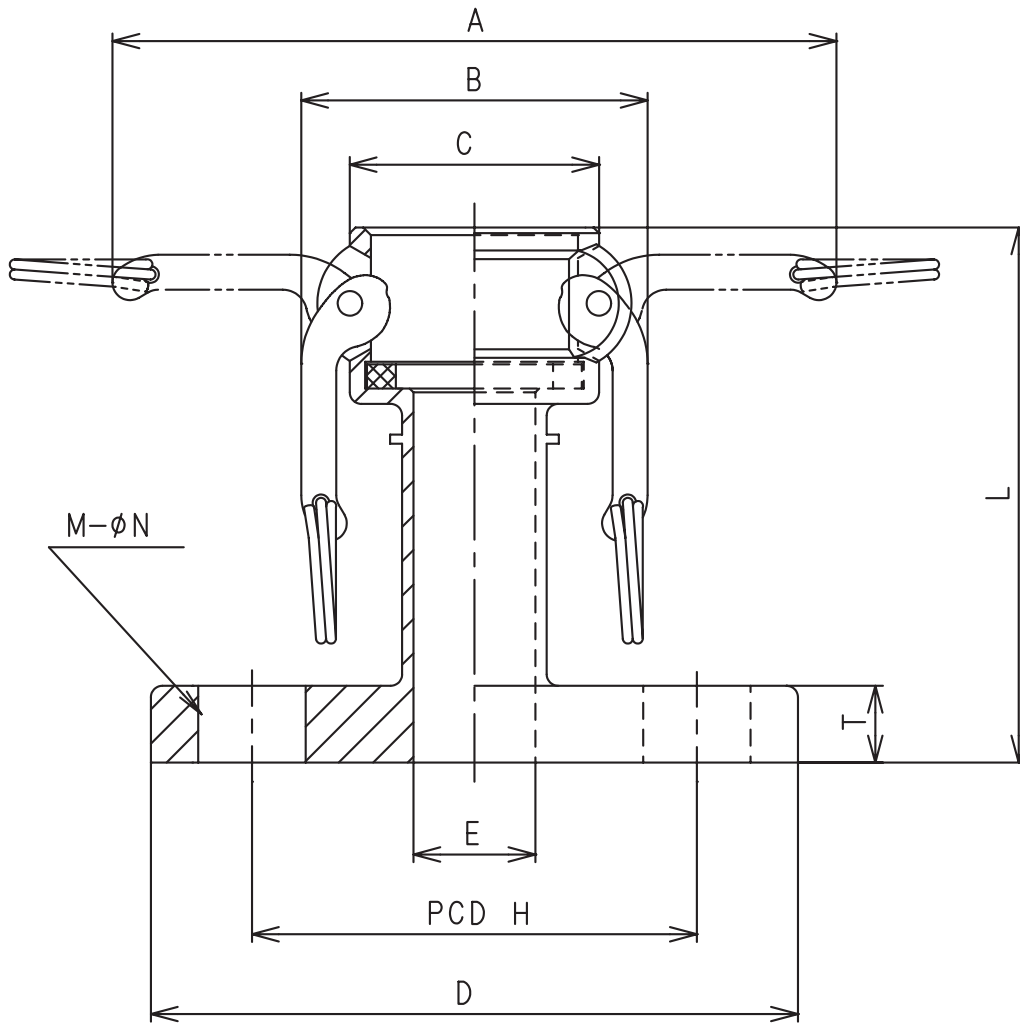

Dimensional sketch for SST Kamlok-couplers·633-LBS												
dim.	1/2"	3/4"	1"	1.1/4"	1.1/2"	2"	2.1/2"	3"	4"	5"	6"	8"
A	116	116	125	181	189	199	210	254	282	307	409	—
B	54	54	61	83	91	101	112	138	166	191	255	—
C	41	41	47	58	65	75	90	108	140	165	198	—
D	95	100	125	135	140	155	175	185	210	250	280	—
E	14	14	20	25	32	45	57	68	89	114	142	—
H	70	75	90	100	105	120	140	150	175	210	240	—
L	93	93	108	120	135	155	158	183	198	188	215	—
M-N	4-15	4-15	4-19	4-19	4-19	4-19	4-19	8-19	8-19	8-23	8-23	—
T	12	14	14	16	16	16	18	18	18	20	22	—

Dimensions in mm.

TITLE WITH JIS10K FLANGE 633-LBS SST	CUSTOMER			NO.
	MAT'L	DRAWN	DATE	REFERENCE
株式会社 トヨックス	WEIGHT	CHECKED		
	SCALE	APPROVED	DWG. NO.	TDS-LBS-92 △