

■選定図

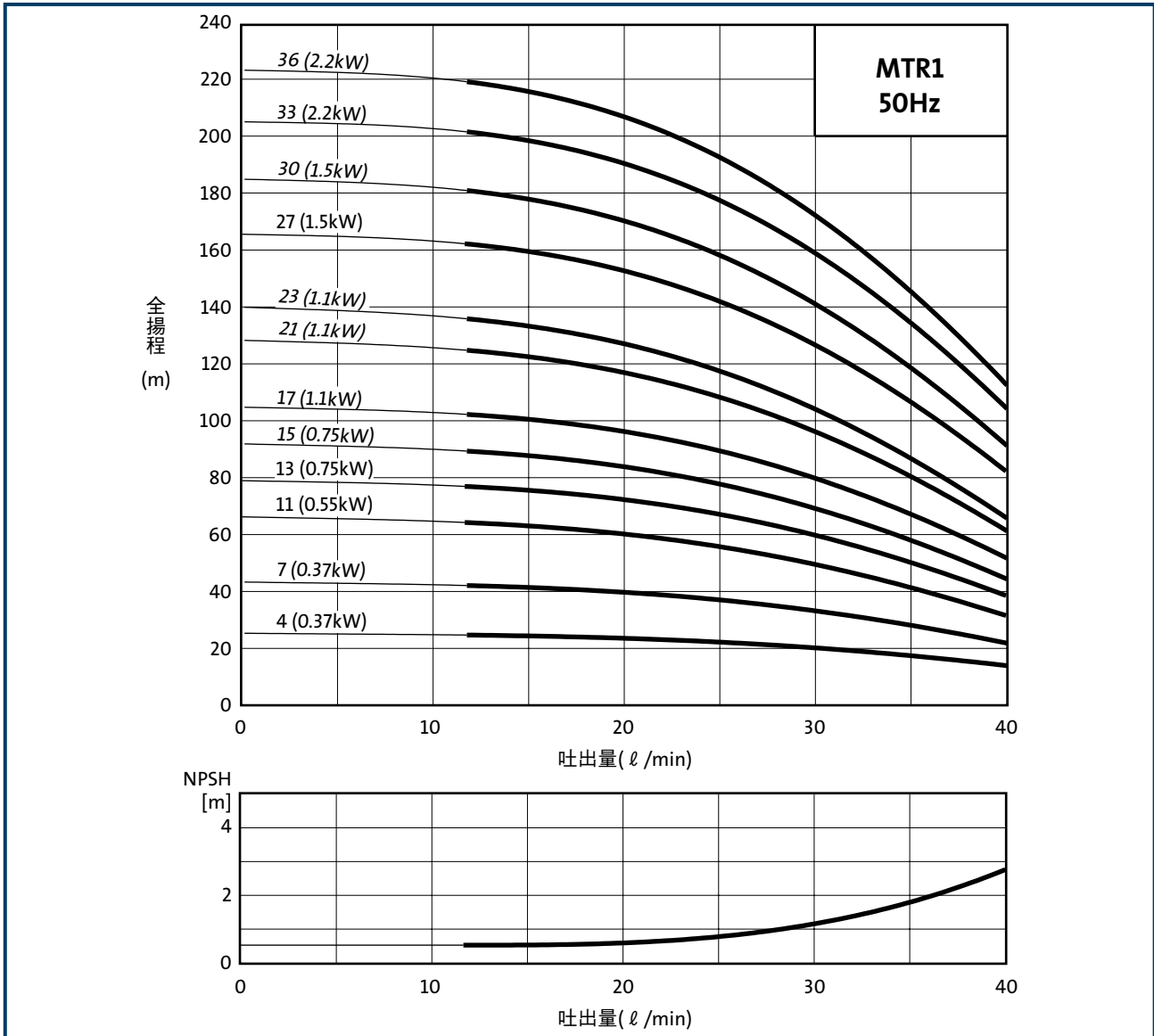

■要目表

型式	吐出口	インペラ数	電動機出力 [kW]	吐出量 [ℓ/min]	全揚程 [m]	吐出量 [ℓ/min]	全揚程 [m]
MTR 1-xx/4	32A (Rp 1 1/4)	4	0.37	12	24.4	40	13.7
MTR 1-xx/7		7	0.37		42		21.6
MTR 1-xx/11		11	0.55		65		32
MTR 1-xx/13		13	0.75		78		39
MTR 1-xx/15		15	0.75		89		44
MTR 1-xx/17		17	1.1		102		51

型式	吐出口	インペラ数	電動機出力 [kW]	吐出量 [ℓ/min]	全揚程 [m]	吐出量 [ℓ/min]	全揚程 [m]
MTR 1-xx/21	32A (Rp 1 1/4)	21	1.1	12	124	40	61
MTR 1-xx/23		23	1.1		135		65
MTR 1-xx/27		27	1.5		163		83
MTR 1-xx/30		30	1.5		181		91
MTR 1-xx/33		33	2.2		201		104
MTR 1-36/36		36	2.2		219		112

■寸法図

MTR 1--A-M-A (標準：鋳鉄製吐出ケーシング)

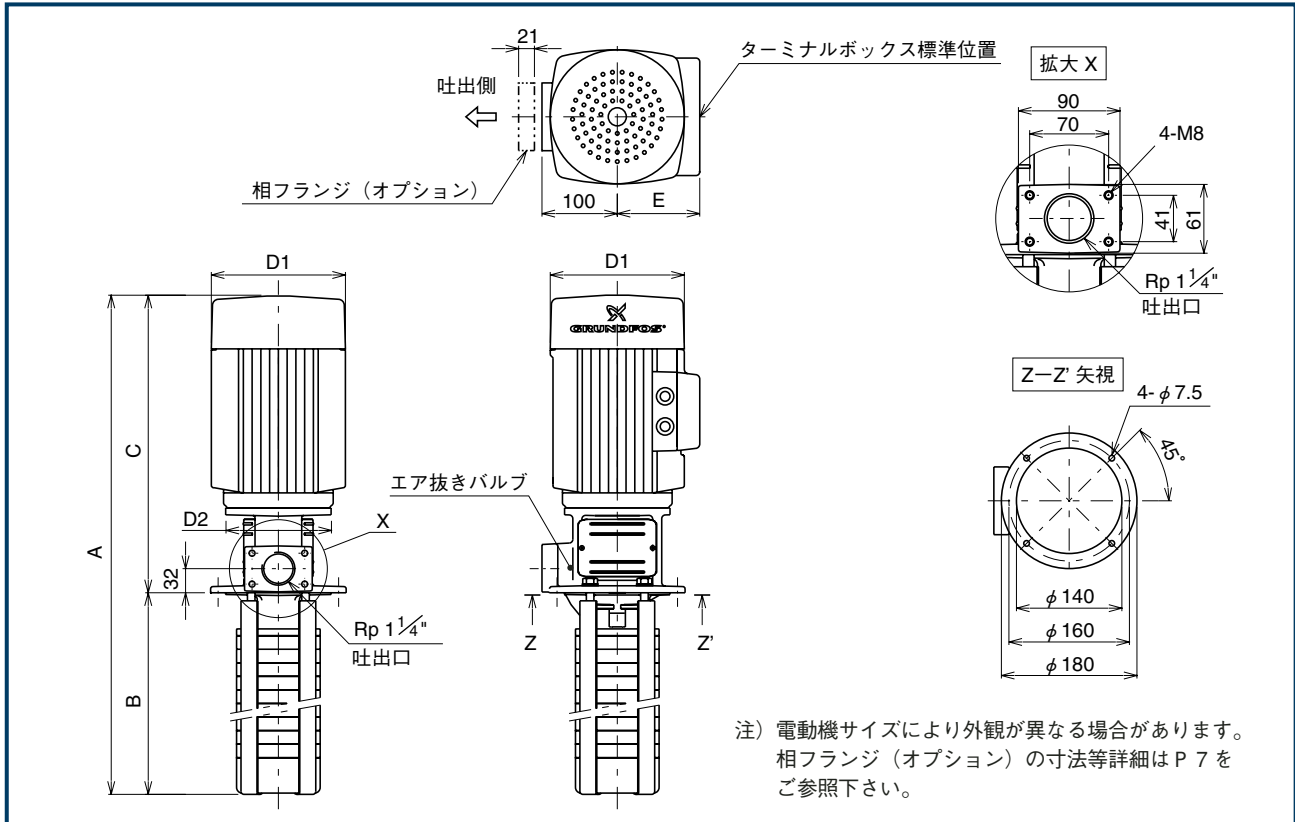

MTR 1--A-W-I (オプション：ステンレス製吐出ケーシング)

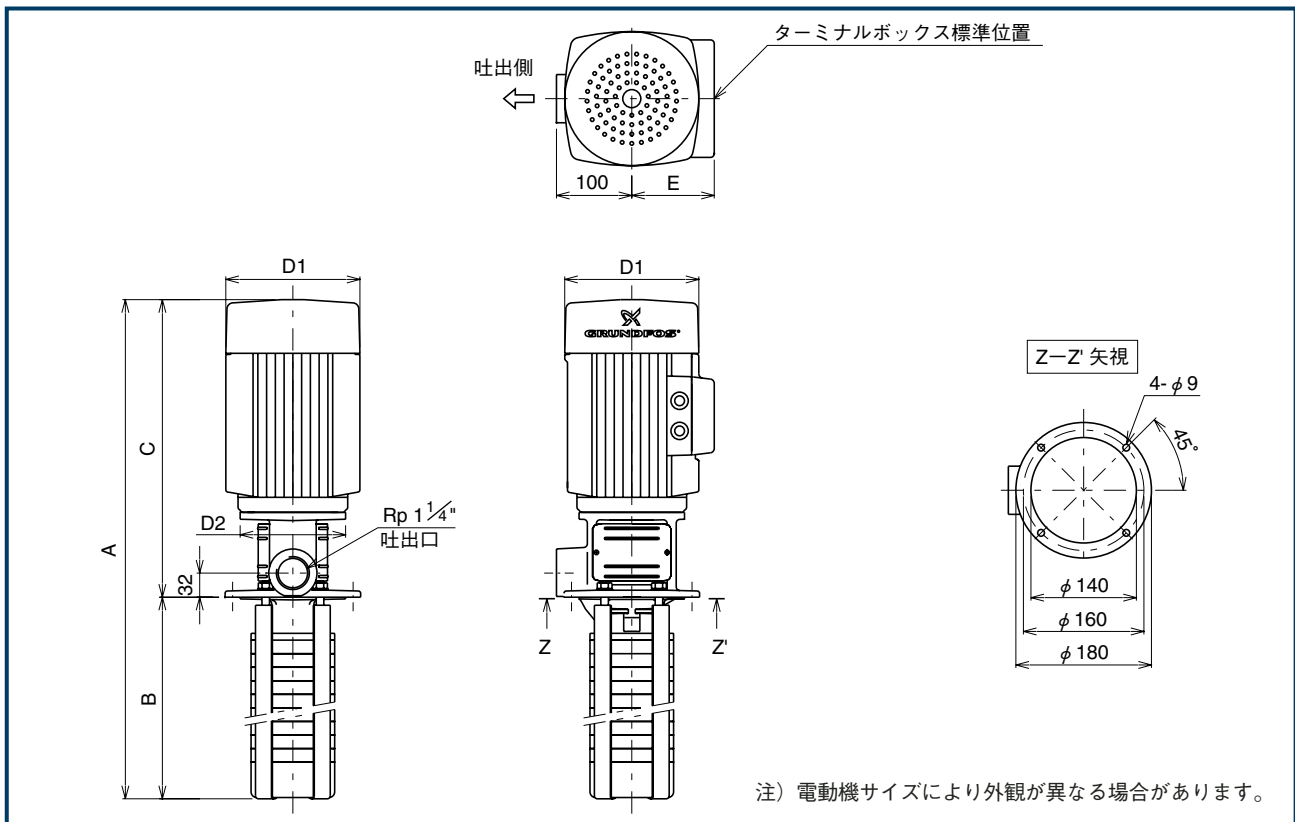

■寸法表

MTR 1 50Hz

型 式	インバー 数	電動機出力 (kW)	寸 法(mm)					概略重量 (kg)	
			A	B	C	D1	D2		E
MTR 1-4/4	4	0.37	500	196	304	141	140	109	13
MTR 1-7/4			554	250					13
MTR 1-9/4			590	286					14
MTR 1-13/4			662	358					14
MTR 1-15/4			698	394					15
MTR 1-17/4			734	430					15
MTR 1-21/4			806	502					16
MTR 1-25/4			878	574					16
MTR 1-7/7	7	0.37	554	250	304	141	140	109	14
MTR 1-9/7			590	286					14
MTR 1-13/7			662	358					15
MTR 1-15/7			698	394					15
MTR 1-17/7			734	430					15
MTR 1-21/7			806	502					16
MTR 1-25/7			878	574					17
MTR 1-11/11			11	0.55					626
MTR 1-15/11	698	394			16				
MTR 1-17/11	734	430			16				
MTR 1-21/11	806	502			17				
MTR 1-25/11	878	574			18				
MTR 1-13/13	13	0.75	702	358	344	141	140	109	17
MTR 1-15/13			738	394					17
MTR 1-17/13			774	430					17
MTR 1-21/13			846	502					18
MTR 1-25/13			918	574					19
MTR 1-15/15	15	0.75	738	394	344	141	140	109	17
MTR 1-17/15			774	430					18
MTR 1-21/15			846	502					18
MTR 1-25/15			918	574					19
MTR 1-17/17			17	1.1					774
MTR 1-21/17	846	502			20				
MTR 1-25/17	918	574			21				
MTR 1-30/17	1008	664			22				
MTR 1-21/21	21	1.1			846	502	344	141	140
MTR 1-25/21			918	574	21				
MTR 1-30/21			1008	664	22				
MTR 1-33/21			1062	718	23				
MTR 1-23/23			23	1.1	882	538			
MTR 1-25/23	918	574			22				
MTR 1-30/23	1008	664			22				
MTR 1-33/23	1062	718			23				
MTR 1-36/23	1116	772			23				
MTR 1-27/27	27	1.5	1004	610	394	178	140	110	31
MTR 1-33/27			1112	718					32
MTR 1-36/27			1166	772					32
MTR 1-30/30			1058	664					32
MTR 1-33/30			1112	718					32
MTR 1-36/30	1166	772	33						
MTR 1-33/33	33	2.2	1152	718	434	178	140	110	38
MTR 1-36/33			1206	772					38
MTR 1-36/36			1206	772					39

MTR 1 60Hz

型 式	インバー 数	電動機出力 (kW)	寸 法(mm)					概略重量 (kg)	
			A	B	C	D1	D2		E
MTR 1-4/4	4	0.37	500	196	304	141	140	109	13
MTR 1-7/4			554	250					13
MTR 1-9/4			590	286					14
MTR 1-13/4			662	358					14
MTR 1-15/4			698	394					15
MTR 1-17/4			734	430					15
MTR 1-21/4			806	502					16
MTR 1-25/4			878	574					16
MTR 1-6/6	6	0.55	536	232	304	141	140	109	14
MTR 1-8/6			572	268					14
MTR 1-10/6			608	304					15
MTR 1-13/6			662	358					15
MTR 1-15/6			698	394					15
MTR 1-17/6			734	430					16
MTR 1-21/6			806	502					16
MTR 1-25/6			878	574					17
MTR 1-8/8	8	0.75	612	268	344	141	140	109	15
MTR 1-10/8			648	304					16
MTR 1-13/8			702	358					16
MTR 1-15/8			738	394					16
MTR 1-17/8			774	430					17
MTR 1-21/8			846	502					18
MTR 1-25/8			918	574					18
MTR 1-10/10			10	1.1					648
MTR 1-13/10	702	358			18				
MTR 1-15/10	738	394			18				
MTR 1-17/10	774	430			18				
MTR 1-21/10	846	502			19				
MTR 1-25/10	918	574	20						
MTR 1-13/13	13	1.1	702	358	344	141	140	109	18
MTR 1-15/13			738	394					19
MTR 1-17/13			774	430					19
MTR 1-21/13			846	502					20
MTR 1-25/13			918	574					20
MTR 1-15/15	15	1.5	788	394	394	178	140	110	27
MTR 1-17/15			824	430					28
MTR 1-21/15			896	502					28
MTR 1-25/15			968	574					29
MTR 1-30/15			1058	664					30
MTR 1-17/17	17	1.5	824	430	394	178	140	110	28
MTR 1-21/17			896	502					29
MTR 1-25/17			968	574					29
MTR 1-30/17			1058	664					30
MTR 1-33/17			1112	718					31
MTR 1-21/21	21	2.2	936	502	434	178	140	110	34
MTR 1-25/21			1008	574					35
MTR 1-30/21			1098	664					36
MTR 1-33/21			1152	718					36
MTR 1-36/21			1206	772					37
MTR 1-23/23	23	2.2	972	538	434	178	140	110	35
MTR 1-27/23			1044	610					36
MTR 1-30/23			1098	664					36
MTR 1-33/23			1152	718					37
MTR 1-36/23			1206	772					37
MTR 1-25/25	25	2.2	1008	574	434	178	140	110	36
MTR 1-27/25			1044	610					36
MTR 1-30/25			1098	664					36
MTR 1-33/25			1152	718					37
MTR 1-36/25			1206	772					37
MTR 1-27/27	27	3.0	1058	610	448	198	160	120	38
MTR 1-30/27			1112	664					39
MTR 1-33/27			1166	718					39
MTR 1-36/27			1220	772					40