

■選定図

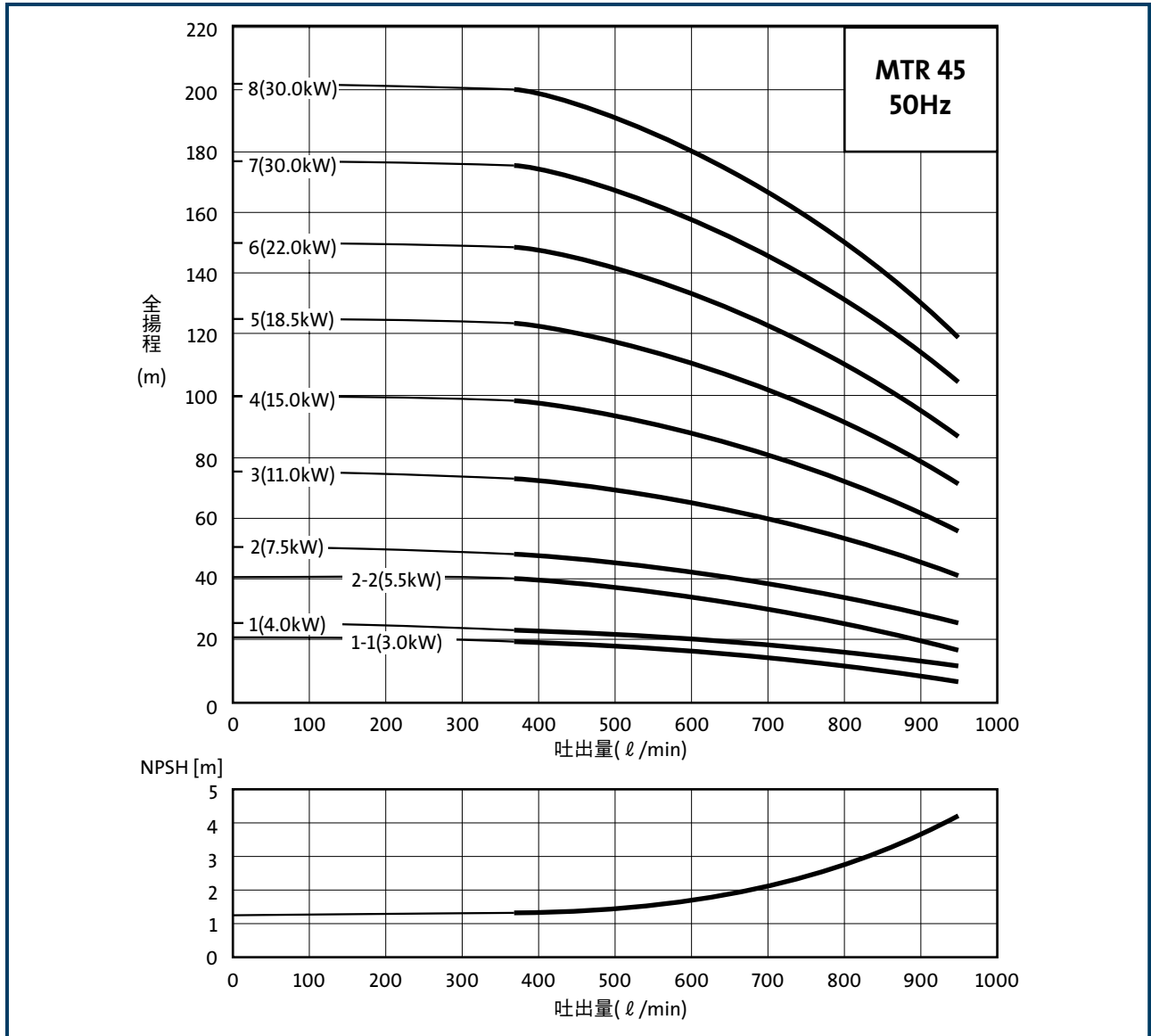

■要目表

型式	吐出口径	インペラ数			出力 kW	吐出量 全揚程		吐出量 全揚程		吐出量 全揚程	
		総数	標準	小径		ℓ/min	m	ℓ/min	m	ℓ/min	m
MTR45	80A	1	0	1	3.0	20	17	12			
		1	1	0	4.0	23	21	16			
		2	0	2	5.5	40	36	25			
		2	2	0	7.5	400	48	600	43	850	33
		3	3	0	11.0		72		66		51
		4	4	0	15.0		98		88		68
		5	5	0	18.5		122		111		87

型式	吐出口径	インペラ数			出力 kW	吐出量 全揚程		吐出量 全揚程		吐出量 全揚程	
		総数	標準	小径		ℓ/min	m	ℓ/min	m	ℓ/min	m
MTR45	80A	6	6	0	22.0	148	133	104			
		7	7	0	30.0	400	173	600	158	850	124
		8	8	0	30.0	198	180				

※ケーシング段数とインペラ枚数の差が大きい時は、上記の数値通りの性能が得られない場合があります。

■寸法図

MTR 45,64

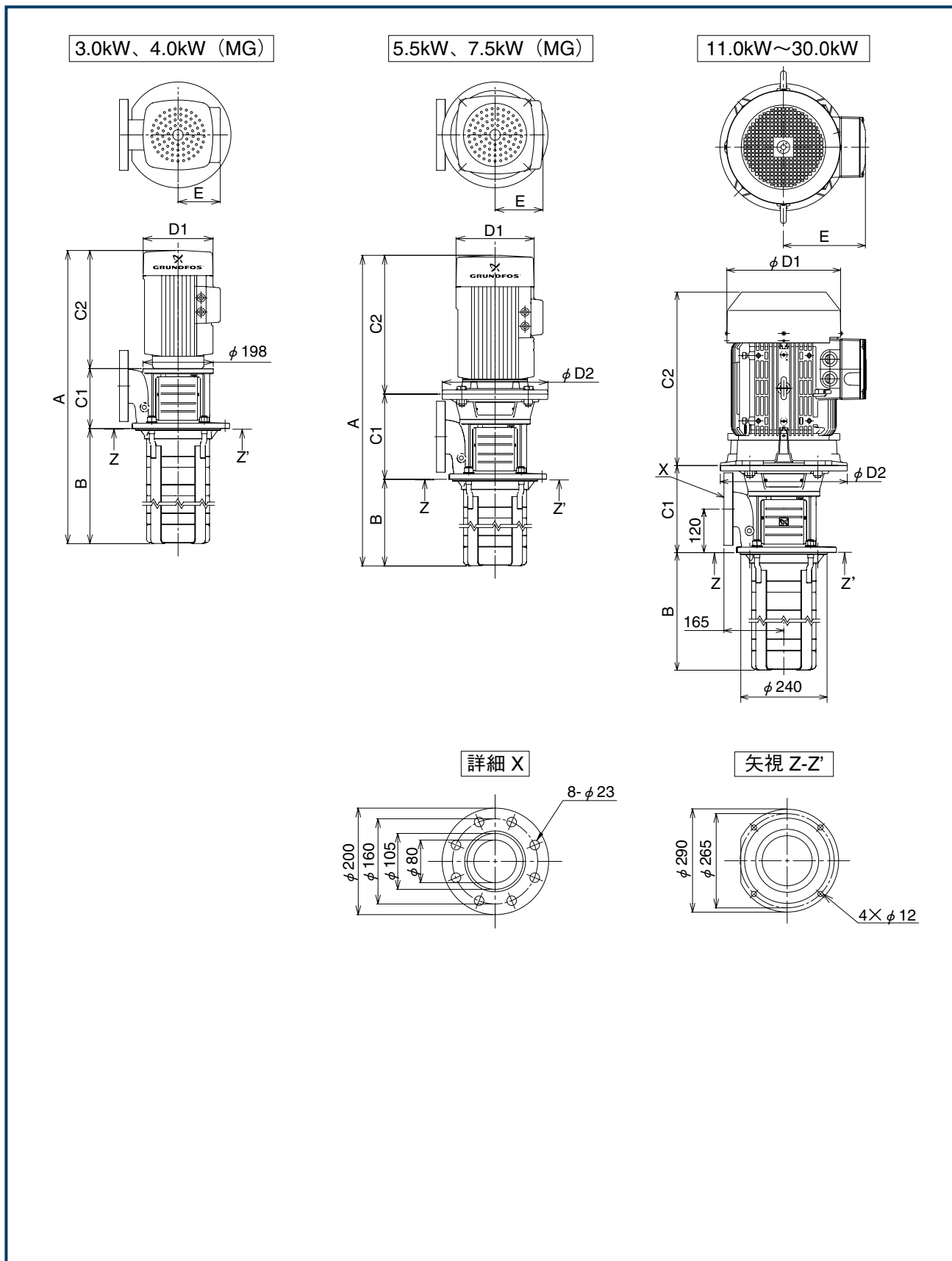

■寸法表

MTR 45 50Hz

型 式	インペラ数			電動機 出力(kW)	寸 法 (mm)							概略質量 (kg)
	総数	標準	小径		A	B	C1	C2	D1	D2	E	
MTR 45-2/1-1					748	244						54
MTR 45-3/1-1					828	324						56
MTR 45-4/1-1					908	404						58
MTR 45-5/1-1	1	0	1	3.0	988	484	169	335	198	—	120	60
MTR 45-6/1-1					1068	564						62
MTR 45-7/1-1					1148	644						64
MTR 45-8/1-1					1228	724						66
MTR 45-2/1					785	244						66
MTR 45-3/1					865	324						68
MTR 45-4/1					945	404						70
MTR 45-5/1	1	1	0	4.0	1025	484	169	372	220	—	134	72
MTR 45-6/1					1105	564						74
MTR 45-7/1					1185	644						76
MTR 45-8/1					1265	724						78
MTR 45-2/2-2					875	244						84
MTR 45-3/2-2					955	324						86
MTR 45-4/2-2					1035	404						88
MTR 45-5/2-2	2	0	2	5.5	1115	484	240	391	220	298	134	90
MTR 45-6/2-2					1195	564						92
MTR 45-7/2-2					1275	644						94
MTR 45-8/2-2					1355	724						96
MTR 45-2/2					875	244						88
MTR 45-3/2					955	324						90
MTR 45-4/2					1035	404						92
MTR 45-5/2	2	2	0	7.5	1115	484	240	391	220	298	134	94
MTR 45-6/2					1195	564						96
MTR 45-7/2					1275	644						98
MTR 45-8/2					1355	724						100
MTR 45-3/3					1042	324						132
MTR 45-4/3					1122	404						134
MTR 45-5/3	3	3	0	11.0	1202	484	240	478	314	350	226	136
MTR 45-6/3					1282	564						138
MTR 45-7/3					1362	644						140
MTR 45-8/3					1442	724						142
MTR 45-4/4					1122	404						144
MTR 45-5/4					1202	484						146
MTR 45-6/4	4	4	0	15.0	1282	564	240	478	314	350	226	148
MTR 45-7/4					1362	644						150
MTR 45-8/4					1442	724						152
MTR 45-5/5					1242	484						163
MTR 45-6/5					1322	564						165
MTR 45-7/5	5	5	0	18.5	1402	644	240	518	314	350	226	167
MTR 45-8/5					1482	724						169
MTR 45-6/6					1406	564						233
MTR 45-7/6	6	6	0	22.0	1486	644	240	602	354	350	330	235
MTR 45-8/6					1566	724						237
MTR 45-7/7					1486	644						280
MTR 45-8/7	7	7	0	30.0	1566	724	240	602	393	400	395	282
MTR 45-8/8	8	8	0	30.0	1566	724	240	602	393	400	395	283

MTR 45 60Hz

型 式	インペラ数			電動機 出力(kW)	寸 法 (mm)							概略質量 (kg)
	総数	標準	小径		A	B	C1	C2	D1	D2	E	
MTR 45-2/1-1					875	244						84
MTR 45-3/1-1					955	324						86
MTR 45-4/1-1					1035	404						88
MTR 45-5/1-1	1	0	1	5.5	1115	484	240	391	220	298	134	90
MTR 45-6/1-1					1195	564						92
MTR 45-7/1-1					1275	644						94
MTR 45-8/1-1					1355	724						96
MTR 45-2/1					875	244						88
MTR 45-3/1					955	324						90
MTR 45-4/1					1035	404						92
MTR 45-5/1	1	1	0	7.5	1115	484	240	391	220	298	134	94
MTR 45-6/1					1195	564						96
MTR 45-7/1					1275	644						98
MTR 45-8/1					1355	724						100
MTR 45-2/2-1					962	244						130
MTR 45-3/2-1					1042	324						132
MTR 45-4/2-1					1122	404						134
MTR 45-5/2-1	2	1	1	11.0	1202	484	240	478	314	350	226	136
MTR 45-6/2-1					1282	564						138
MTR 45-7/2-1					1362	644						140
MTR 45-8/2-1					1442	724						142
MTR 45-2/2					962	244						139
MTR 45-3/2					1042	324						141
MTR 45-4/2					1122	404						143
MTR 45-5/2	2	2	0	15.0	1202	484	240	478	314	350	226	145
MTR 45-6/2					1282	564						147
MTR 45-7/2					1362	644						149
MTR 45-8/2					1442	724						151
MTR 45-3/3					1082	324						158
MTR 45-4/3					1162	404						160
MTR 45-5/3	3	3	0	18.5	1242	484	240	518	314	350	226	162
MTR 45-6/3					1322	564						164
MTR 45-7/3					1402	644						166
MTR 45-8/3					1482	724						168
MTR 45-4/4-2					1246	404						228
MTR 45-5/4-2					1326	484						230
MTR 45-6/4-2	4	2	2	22.0	1406	564	240	602	354	350	330	232
MTR 45-7/4-2					1486	644						234
MTR 45-8/4-2					1566	724						236
MTR 45-5/5					1326	484						275
MTR 45-6/5					1406	564						277
MTR 45-7/5	5	5	0	30.0	1486	644	240	602	393	400	395	279
MTR 45-8/5					1566	724						281

■寸法表

MTR 64 50Hz

型 式	インベラ数			電動機 出力(kW)	寸 法 (mm)							概略質量 (kg)
	総数	標準	小径		A	B	C1	C2	D1	D2	E	
MTR 64-2/1-1					790	249						66
MTR 64-3/1-1					873	332						68
MTR 64-4/1-1					955	414						70
MTR 64-5/1-1	1	0	1	4.0	1038	497	169	372	220	—	134	72
MTR 64-6/1-1					1120	579						74
MTR 64-7/1-1					1203	662						76
MTR 64-8/1-1					1285	744						78
MTR 64-2/1					880	249						84
MTR 64-3/1					963	332						86
MTR 64-4/1					1045	414						88
MTR 64-5/1	1	1	0	5.5	1128	497	240	391	220	298	134	90
MTR 64-6/1					1210	579						92
MTR 64-7/1					1293	662						94
MTR 64-8/1					1375	744						96
MTR 64-2/2-2					880	249						88
MTR 64-3/2-2					963	332						90
MTR 64-4/2-2					1045	414						92
MTR 64-5/2-2	2	0	2	7.5	1128	497	240	391	220	298	134	94
MTR 64-6/2-2					1210	579						96
MTR 64-7/2-2					1293	662						98
MTR 64-8/2-2					1375	744						100
MTR 64-2/2					967	249						130
MTR 64-3/2					1050	332						132
MTR 64-4/2					1132	414						134
MTR 64-5/2	2	2	0	11.0	1215	497	240	478	314	350	226	136
MTR 64-6/2					1297	579						138
MTR 64-7/2					1380	662						140
MTR 64-8/2					1462	744						142
MTR 64-3/3-1					1050	332						141
MTR 64-4/3-1					1132	414						143
MTR 64-5/3-1	3	2	1	15.0	1215	497	240	478	314	350	226	145
MTR 64-6/3-1					1297	579						147
MTR 64-7/3-1					1380	662						149
MTR 64-8/3-1					1462	744						151
MTR 64-3/3					1090	332						158
MTR 64-4/3					1172	414						160
MTR 64-5/3	3	3	0	18.5	1255	497	240	518	314	350	226	162
MTR 64-6/3					1337	579						164
MTR 64-7/3					1420	662						166
MTR 64-8/3					1502	744						168
MTR 64-4/4					1256	414						229
MTR 64-5/4					1339	497						231
MTR 64-6/4	4	4	0	22.0	1421	579	240	602	354	350	330	233
MTR 64-7/4					1504	662						235
MTR 64-8/4					1586	744						237
MTR 64-5/5					1339	497						276
MTR 64-6/5	5	5	0	30.0	1421	579	240	602	393	400	395	278
MTR 64-7/5					1504	662						280
MTR 64-8/5					1586	744						282

MTR 64 60Hz

型 式	インベラ数			電動機 出力(kW)	寸 法 (mm)							概略質量 (kg)
	総数	標準	小径		A	B	C1	C2	D1	D2	E	
MTR 64-2/1-1					880	249						88
MTR 64-3/1-1					963	332						90
MTR 64-4/1-1					1045	414						92
MTR 64-5/1-1	1	0	1	7.5	1128	497	240	391	220	298	134	94
MTR 64-6/1-1					1210	579						96
MTR 64-7/1-1					1293	662						98
MTR 64-8/1-1					1375	744						100
MTR 64-2/1					967	249						130
MTR 64-3/1					1050	332						132
MTR 64-4/1					1132	414						134
MTR 64-5/1	1	1	0	11.0	1215	497	240	478	314	350	226	136
MTR 64-6/1					1297	579						138
MTR 64-7/1					1380	662						140
MTR 64-8/1					1462	744						142
MTR 64-2/2-2					967	249						139
MTR 64-3/2-2					1050	332						141
MTR 64-4/2-2					1132	414						143
MTR 64-5/2-2	2	0	2	15.0	1215	497	240	478	314	350	226	145
MTR 64-6/2-2					1297	579						147
MTR 64-7/2-2					1380	662						149
MTR 64-8/2-2					1462	744						151
MTR 64-2/2-1					1007	249						156
MTR 64-3/2-1					1090	332						158
MTR 64-4/2-1					1172	414						160
MTR 64-5/2-1	2	1	1	18.5	1255	497	240	518	314	350	226	162
MTR 64-6/2-1					1337	579						164
MTR 64-7/2-1					1420	662						166
MTR 64-8/2-1					1502	744						168
MTR 64-2/2					1091	249						224
MTR 64-3/2					1174	332						226
MTR 64-4/2					1256	414						228
MTR 64-5/2	2	2	0	22.0	1339	497	240	602	354	350	330	230
MTR 64-6/2					1421	579						232
MTR 64-7/2					1504	662						234
MTR 64-8/2					1586	744						236
MTR 64-3/3					1174	332						271
MTR 64-4/3					1256	414						273
MTR 64-5/3	3	3	0	30.0	1339	497	240	602	393	400	395	275
MTR 64-6/3					1421	579						277
MTR 64-7/3					1504	662						279
MTR 64-8/3					1586	744						281